

AdvanMux-16™

16 port RFID UHF multiplexer



Product overview

AdvanMux-16 is a high performance 16 port multiplexer that expands by a factor 16 the number of antennas that can be connected to each port of an RFID reader.

AdvanMux-16 is compatible with most RFID reader models in the market, including Keonn's AdvanReader, Impinj, Sirit, Motorola, ThingMagic Mercury6, and others.

AdvanMux-16 is connected to the I/O port of most reader models, and it is controlled by sending simple commands to the reader. This facilitates the control of AdvanMux-16 and its synchronization with the reader. Any port of AdvanMux-16 can be selected at any time.

AdvanMux-16 can be directly connected to AdvanReader-100 and AdvanReader-150 through a conventional Ethernet cable.

For other reader models, a reader-specific cable adapter or the AdvanGPIO connection board can be ordered that connect the digital I/O port of the reader to one of the two RJ45 control ports of AdvanMux-16 multiplexer. The following picture shows the cable adapter for a specific reader model and the AdvanGPIO connection board.



Benefits:

- Reduces the cost of RFID applications with many antennas
- Very fast and easy connection
- Compatible with most reader models
- Easy selection of ports by sending proper commands to the reader
- Easy control of several multiplexers by interconnecting them with standard Ethernet cables
- Low insertion loss

The cable adapter can be easily extended to the required length using regular Ethernet 8-wire cables.

Two RJ45 control connectors are available at each AdvanMux-16 so that one multiplexer can control and power another multiplexer by a simple Ethernet 8-wire cable connection (see diagram below).

Applications:

- Radiofrequency systems that require more than 4 antennas
- RFID systems in general
- Smart shelves
- Smart cabinets
- Smart surfaces
- Portals

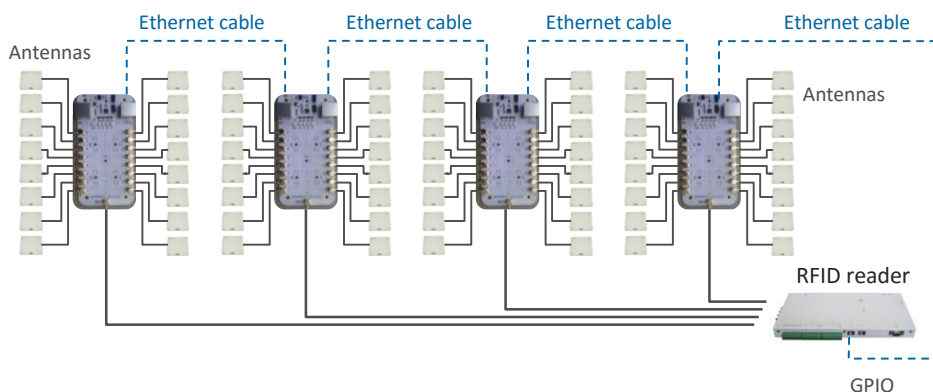

AdvanMux-16 can be controlled both by standard +5 V and open collector digital outputs.

AdvanMux-16 can be powered from +5 V DC to + 48 V DC. This power can be obtained from a power supply or by the available voltage in some reader's I/O ports.

The input RF connector and the 16 output RF connectors are SMA (female).

Four red LED diodes show the digital-in status and one white LED shows the power on status.

AdvanMux-16™

16 port RFID UHF multiplexer



Specifications

Operating frequency	860 MHz to 950 MHz
Number of ports	16
Insertion loss	<1.4 dB (1.2 dB typ.)
Isolation	> 35 dB
Return loss	> 19.5 dB (22 dB typ.)
Max input power	33 dBm
Switching time	< 15 μ s
RF connectors	1 input and 16 output SMA 50 ohm female connectors
Control and power connector	2 input/output RJ45 connectors (Table 1)
Power supply	RJ45 IN connector pin 4 and/or pin 5: 5 V (-2 %) to 48 V (+5 %) (regulated on board)
Current consumption	< 12 mA
Digital inputs	0 V/5 V TTL/3 V TTL or open collector Note: Reader outputs must sink 2 mA (maximum)
Connection to AdvanReader-100 and AdvanReader-150	Requires only a conventional Ethernet cable AdvanReader allows using two-level AdvanMux-16 multiplexing, so that up to 1024 antennas can be connected to the same reader
Connection to Impinj R220 & R420, ThingMagic Mercury 6	Requires a cable adapter (available upon request) and a conventional Ethernet cable (UTP cable)
Connection to other readers	Compatibility with most readers. Requirements: - AdvanGPIO connection board (available upon request), and for some reader models PoE injector (available upon request)
Cable adapter	Optional. Length: 25 cm (10 inches)
Control connection between AdvanMux units	Through standard Ethernet 8-wire UTP cables
Electrostatic discharge protection	> 2kV ESD protection on all RF ports
Size with enclosure	145 mm x 75mm x 25 mm (5.7 inches x 3 inches x 1 inch)
Size without enclosure	137 mm x 75 mm x 17 mm (5.4 inches x 3 inches x 0.7 inch)
Weight with enclosure	240 g
Weight without enclosure	107 g
Operating temperature	-30 °C to 55 °C
Storage temperature	-35 °C to 85 °C
EU Directives	RoHS compliant (2002/95/EC), EMC (2004/108/EC)

RJ45 pin out

RJ45 pin number	AdvanMux-16 signal
1	B0
2	B1
3	B2
4	Vcc
5	Vcc
6	B3
7	GND
8	GND

Table 1

AdvanMux-16™

16 port RFID UHF multiplexer



Product codes for ordering

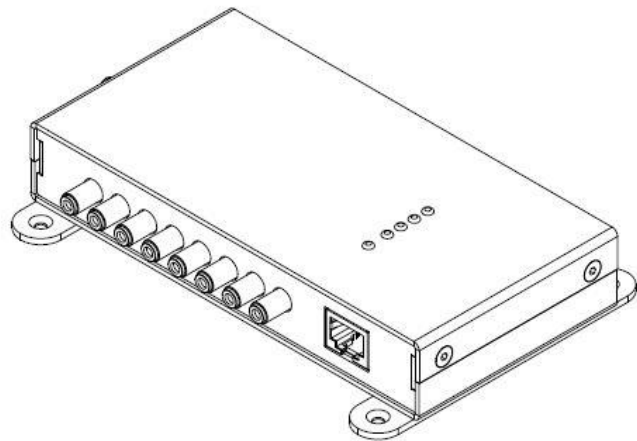
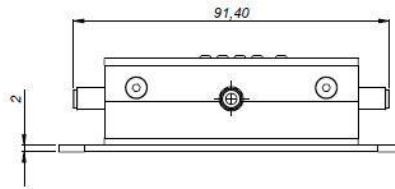
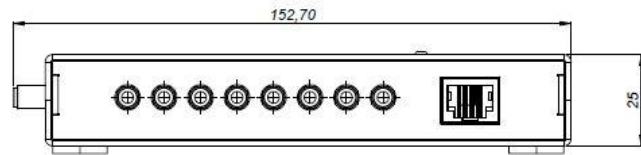
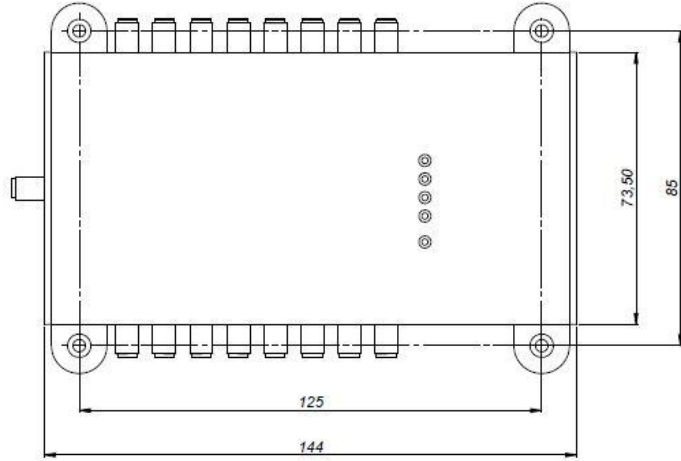

Units in millimeters

Follow us on twitter: @KeonnTech

AdvanMux-16™

16 port RFID UHF multiplexer



Product codes for ordering

ADMX	-	NP	-	F	-	mmm	
							NP = Number of Ports
		4					4 ports
		8					8 ports
		12					12 ports
		16					16 ports
							F = Frame
				e			enclosure
							no enclosure
							Model
						110	Model number
						120	(only for AdvanMux-12)

Example:

- **ADMX-16-e-110:**
 - AdvanMux
 - 16 ports
 - with enclosure
 - Model 110