

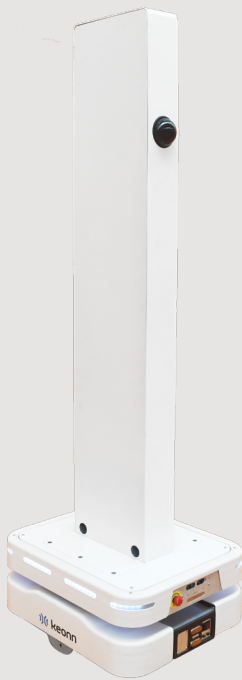

**keonn** Retail RFID  
Systems

**Robin-200™**  
RFID robot for  
automatic inventory





U.S. patent 9939816

[Video](#)

### Benefits:

- Increased RFID inventory accuracy compared to handheld readers
- 2D automatic inventory
- Cost reduction in inventory taking
- Fast and easy detection of misplaced items
- Acceleration of picking for return management
- Easily moves around any given space
- Synchronized tag reading and movement
- Very high read rate

### Applications:

- Retail stores
- Low-ceiling warehouses

### Product overview

RFID inventory accuracy with handheld RFID readers could be in excess of 98%, but process missteps and human errors decrease that accuracy to 85% - 95%.

Robin-200 is a mobile and autonomous RFID system that performs automatically the **inventory** of a given space, for instance, a retail store or a low-ceiling warehouse, that provides a higher RFID inventory accuracy than handheld readers.

It operates completely autonomously: the user indicates when inventories should be taken and the robot starts when it is scheduled. After each inventory, the robot goes back to its docking station to charge.

Robin-200 also **locates** each tagged item in 2 dimensions (x and y). This information can be processed to generate a planogram of the items inside a space.

The information generated by Robin can be used to help employees detecting misplaced items, to accelerate picking and return management, for money mapping purposes, and other operational processes.

Robin-200 can **move in all directions**, since it can rotate without displacement. Therefore, it can easily move around any given space.

The speed is **synchronized with tag reading** in order to maximize read rate. Robin has a modular design for ease of maintenance and transport.

Robin-200 **includes**:

- RFID system with 8 antennas, 4 on each side, capable of achieving very high read rate and a high location accuracy
- Navigation system
- Anti-collision sensors
- App for controlling Robin with a smart phone or tablet
- Energy storage and docking station

### How does it work?



1. The first time operating on a new space, moves Robin across the space using the interface app. In this first step, the RFID subsystem is not operating.
2. This navigation guided by the user allows Robin to generate automatically a map of the space. This mapping process only needs to be performed again if the layout of the space changes significantly.

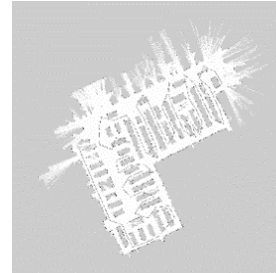

3. The user schedules when Robin should perform inventories. For instance, everyday at 8pm. At the indicated time, Robin starts moving autonomously across the space, reading and locating the RFID tags and storing this information.
4. When it has finished the inventory, it navigates back to its docking station to charge.

### Radiofrequency specifications

Air Protocol Interface	EPCglobal UHF Class 1 Gen 2 / ISO 18000-6C
Supported regions	FCC (NA, SA) 902 MHz - 928 MHz ETSI (EU, IN) 865.6 MHz - 867.6 MHz MIC (KR) 910 MHz - 914 MHz SRRCC-MII (P.R.China) 920 MHz - 925 MHz Brazil: 902-907.5 MHz and 915-928 MHz (by using channel selection) ACMA (AU, NZ) 920 MHz - 926 MHz Open region
RF connections	Four 50 ohm SMA connectors for monostatic antennas
RF Power	Programmable from 5 dBm to 31.5 dBm in 0.5 dBm steps. (Maximum power may have to be reduced to meet regulatory limits)
Max tag read distance	Up to 10 m (33 feet)
Max tag read throughput	Up to 400 tags/second
Number of antennas	8 antennas, 4 on the right side and 4 on the left side
Radiation pattern of each antenna	Wide beam in both directions in one hemisphere
Beamwidth	70° / 70°
Gain	8.3 dBi
Polarization	Circular
Data communications	Ethernet: IEEE 802.3 up to 100 Mbps Wifi: IEEE 802.11 b/g, WEP security, IEEE 802.11i-PSK, WPA-PSK, TKIP
Power	On-board rechargeable batteries
Temperature	0 °C to +50 °C

### Radiofrequency specifications

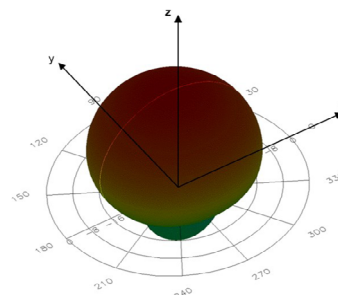

\*Radiation pattern of a single antenna. In the system antennas are installed over metal plate, which eliminates back lobe radiation.

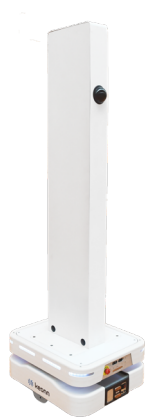

### Mobility specifications

Max speed	0.25m/s
Tractor wheels	2
Caster Wheels	4
Battery	48V 30Ah Li-Ion +6h of operation
Laser	3D, 150m range Lidar, 180°
RGB-D	2xSony
Software	Linux based Robin Operating System

### Mechanical specifications

Dimensions	Mounted: 655 mm x 550 mm x 1947 mm
	Base: 655 x 550 x 300 mm
	Tower: 335.50 mm x 125 mm x 1647 mm
Packaging dimensions	Base: 710 x 815 x 490 mm
	Tower 1886 x 460 x 606 mm

## Mechanical specifications

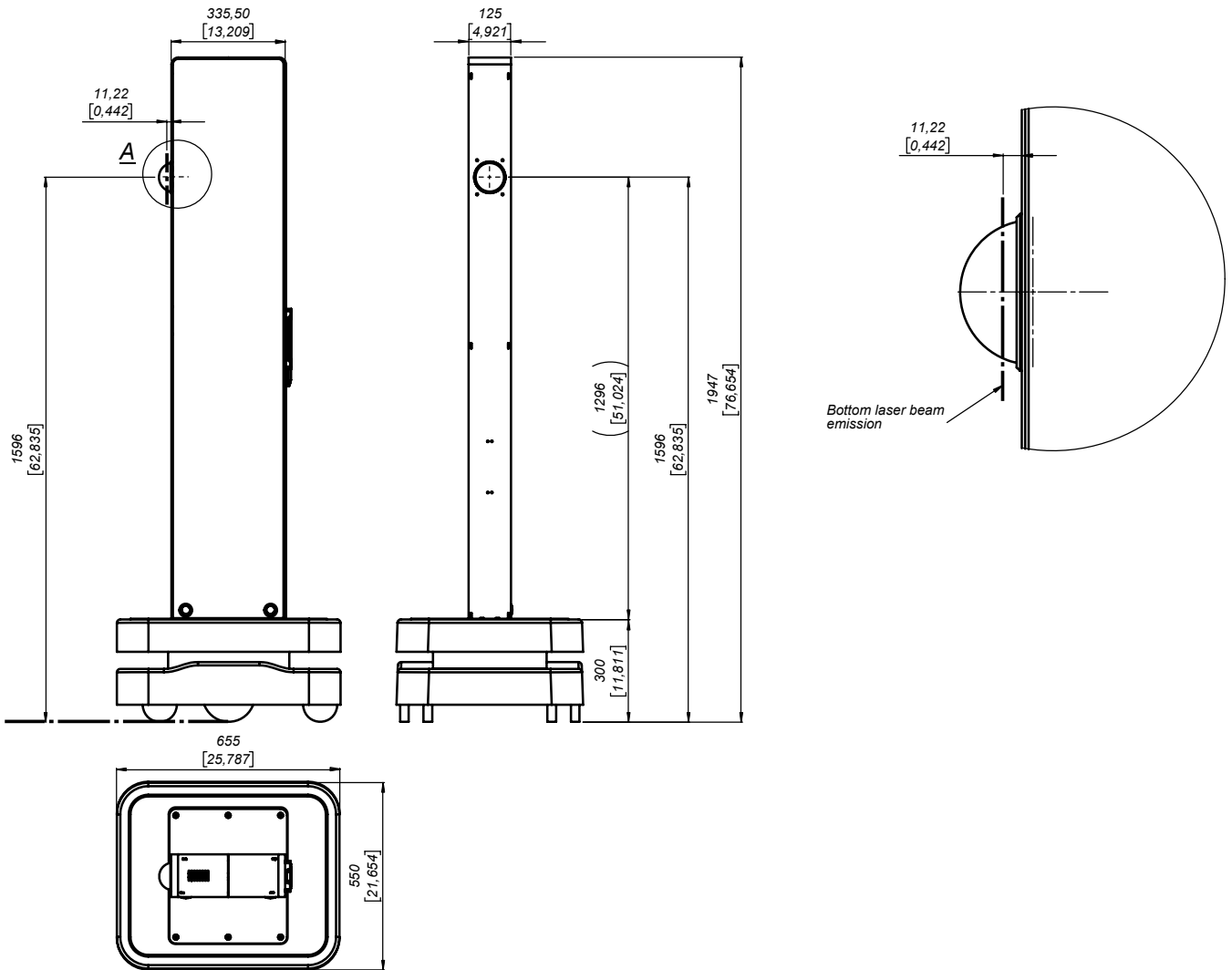

Units in millimeters and [inches]

### Product codes for ordering

ADRT	-	FF	-	mmm	
					<b>FF = frequency band</b>
		EU			865.6 MHz – 867.6 MHz
		US			902.0 MHz – 928.0 MHz
					<b>mmm = Model</b>
				200	Model number

Examples:

#### ADRT-EU-200:

- ADRT
- Frequency band : 865,6 MHz - 867,6 MHz
- Model 200



Copyright © Keonn Technologies S.L.  
All rights reserved.

Information in this publication  
supersedes all earlier versions.  
Specifications subject to change  
without notice.

